

# MARINE PRODUCT DATA SHEET

**OEM:** 1700-020-030 (1100 GPH)  
**AFTERMARKET:** 1700-021-030 (1100 GPH)

## **APPLICATION**

12V DC Bait/Livewell tanks water circulation

## **PUMP**

Type: Centrifugal Pump, Magnetic Drive  
Outlet Port: 1-1/8" Barb  
Inlet Port: 3/4" NPT-M  
Wash-Down Port: 1/2" NPT-F  
Liquid: 130 °F [54 °C] Max  
Prime: Flooded Inlet  
Inlet PSI: 30 PSI [2.1 Bar] Max  
Run Dry: Yes

## **ELECTRICAL**

Motor: 12VDC Permanent Magnet,  
Continuous Duty  
Protection: Need External Fuse (Not supplied)  
Leads: 6 ft [1.8M] Tinned, Twisted Jacketed Cable  
Fuse: 6 Amp Recommended  
Control: No Control

## **MATERIALS**

Housing: High Strength Nylon  
Impeller: Acetal  
Hardware: Stainless Steel

## **APPROVALS**

Ignition Protected 8846, CE

## **SHIPPING**

Approx. Net Weight: 2.5 Lbs. [1.1 Kg] each  
Approx. Lbs./Ctn. 14 Lbs. [6.3 Kg]  
Pumps in Carton: 6  
Approx. Carton Size: 16"L x 11"W x 11" H  
[41cm x 28 cm x 28 cm]

## **RELATED DOCUMENTS**

Catalog: MS-030-140  
Applications Spec Guide: MS-020-005  
Installation Manual: 911-466  
Aftermarket Warranty: 911-1045



The Bait Sentry Livewell Pumps are designed for easy installation and trouble-free operation. Magnetic Drive technology eliminates unnecessary failures. Motors keep running after ingesting debris or even when running dry. Patented anti-airlock feature allows the pump to clear trapped air in rough water or when boat is anchored. Includes dual port for easy washdown pump connection.

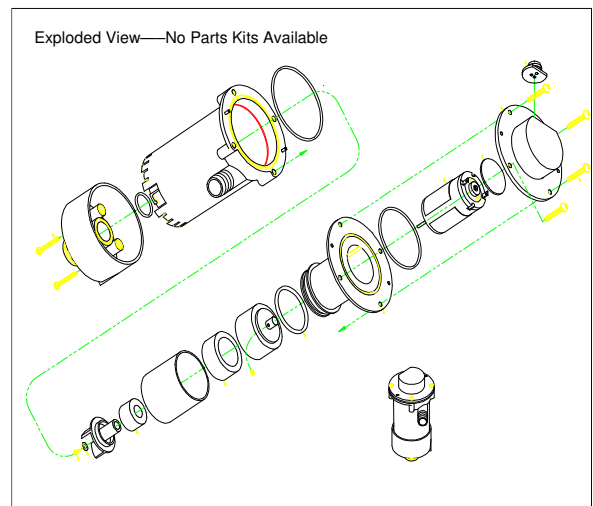

### TYPICAL PERFORMANCE

PRESSURE		FLOW		CURRENT
METERS	FT OF HEAD	GPH	LPH	AMPS
0.0	0	1100	3028	4.2
1.5	5	650	2460	3.7
3.9	13	0	0	2.8

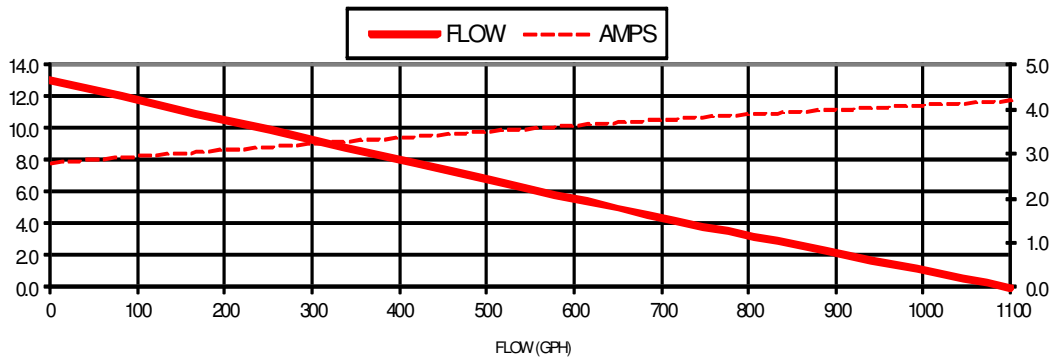

### DIMENSIONS [mm]

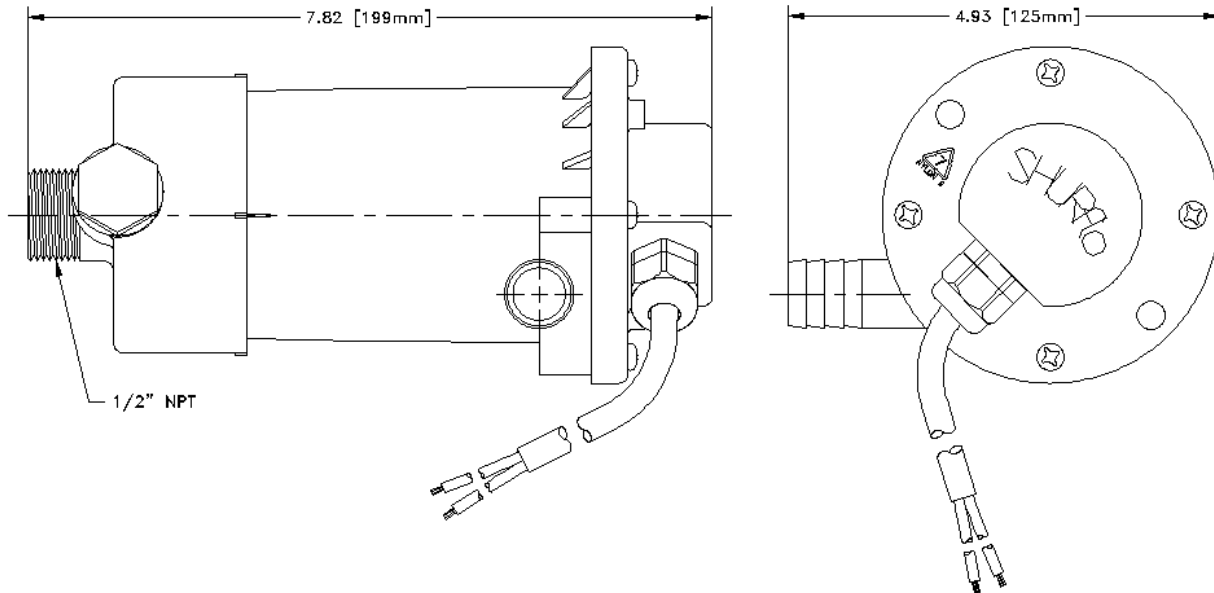

3545 Harbor Gateway South, Suite 103, Costa Mesa, CA 92626, (800) 854-3218 [www.SHURFLO.com](http://www.SHURFLO.com)

All Pentair trademarks and logos are owned by Pentair, Inc. All other brand or product names are trademarks or registered marks of their respective owners. Because we are continuously improving our products and services, Pentair reserves the right to change specifications without prior notice. Pentair is an equal opportunity employer.

1700-020-030 [021] Rev. 12/16 2001 - 2016 ©Pentair, Inc. All Rights Reserved.